

# User Manual

## Changing Shock Absorber Kit

*Easyrig*

Designed and made in Sweden

[www.easyrig.com](http://www.easyrig.com)

### Choosing Shock Absorber

EASYRIG is equipped with specially adapted shock absorbers for different camera weights. Only **one** shock absorber kit is delivered with each EASYRIG. If you change camera weight class, you can order an extra shock absorber kit and change it yourself. Use the table below to choose your shock absorber kit.

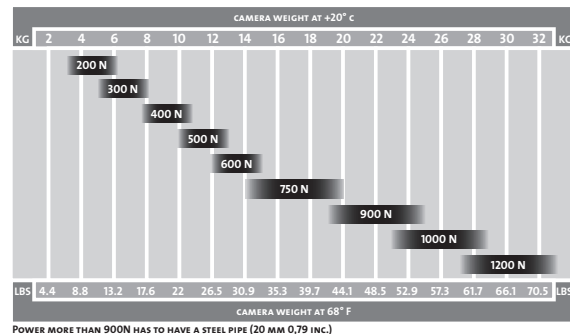

**Included in the complete kit:** Gas shock absorber, line Wheel with ball bearings and attachment clips, suspension line and coil spring tool for mounting the suspension line.

### Dismantling when changing shock absorber kit



**D1** Loosen the adjustment screws on the back support bar and remove the vest.

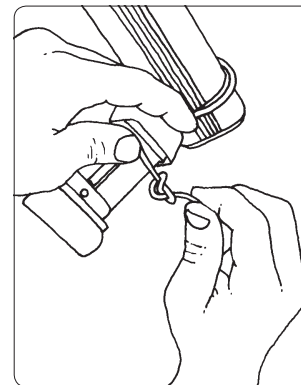

**D3** Detach the snap lock by untying the knot and let the line go in.

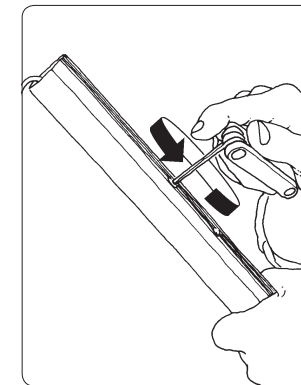

**D5** Remove the two screws which hold the shock absorber kit.

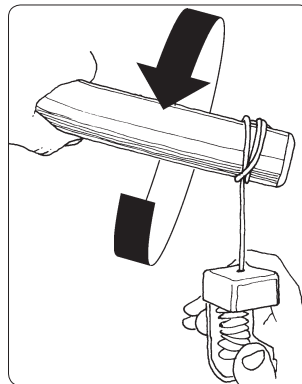

**D2** Extend the suspension line and hold it there by winding it around the support arm.

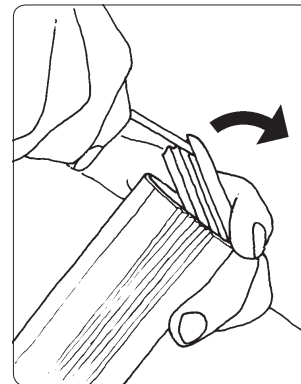

**D4** Remove the plastic plugs at the front of the support arm, and at the end of the back support bar.

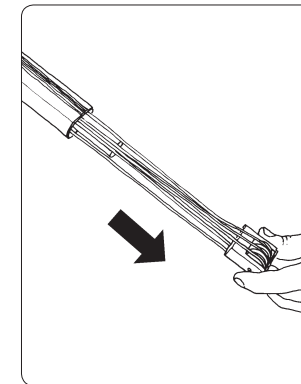

**D6** The shock absorber kit is now free. Remove the whole kit and the whole suspension line.

## Reassembling

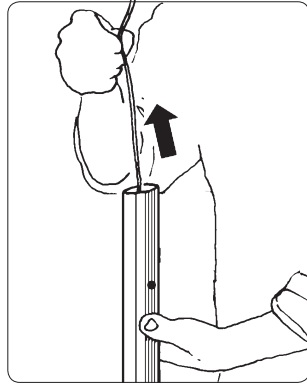

**R1** Unpack your shock absorber kit. Attach the suspension line to the coil spring tool. Feed the coil spring tool into the back support bar from below. Pull the new shock absorber kit in place.

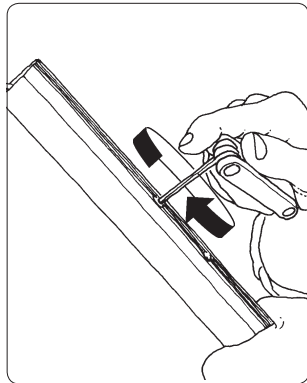

**R2** Fasten the new shock absorber kit with the two screws.

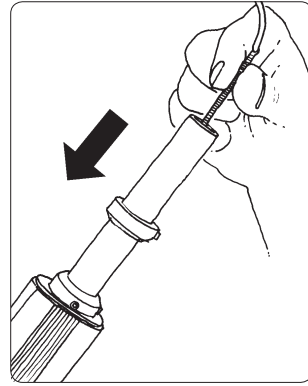

**R3** Continue to feed the coil spring tool into the support arm from below over the line wheel.

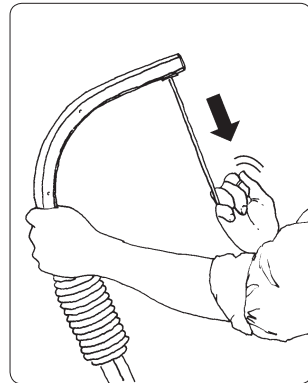

**R4** Check that the line runs smoothly by pulling it gently.

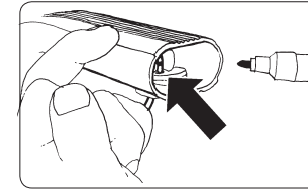

**R5** With the suspension line tight, make a mark where to put the camera hook.

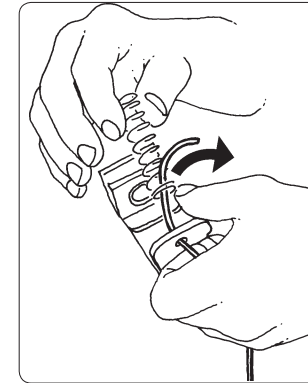

**R6** Wrap the suspension line around the support arm (see section D1) to relieve the tension. Tie a new knot on the mark and attach the plastic cover to hide the knot.

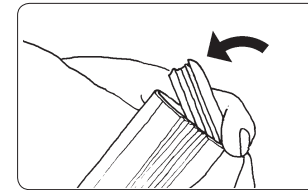

**R7** Replace the plastic plugs.

*Easyrig*

## Specifications

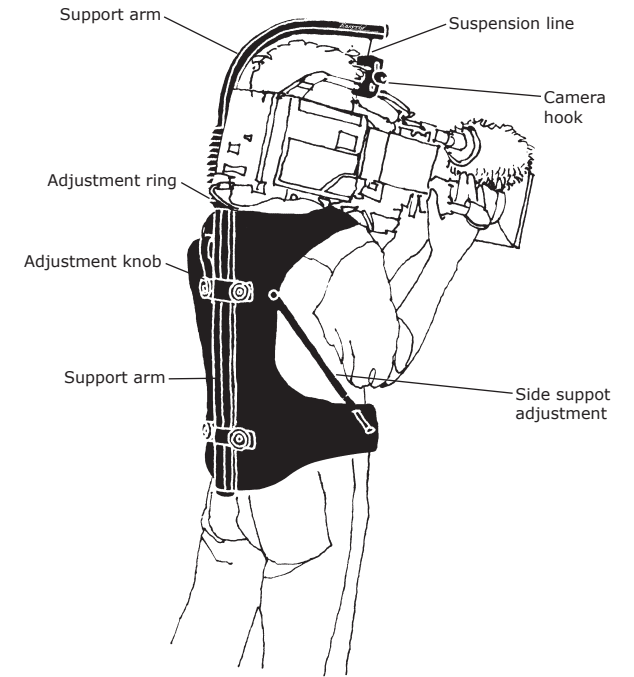

Weight depending on type ..... ≈ 3-4 kg (6,6-8,8 lbs)  
 Height..... 90-100 cm (2'11"-3'3")  
 Suspension line .....88 cm (2'10")  
 .....More information under downloads.

Made in Sweden